

2023/03/14 (rev. 1.02)

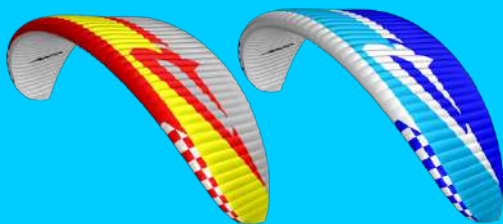

# Manual



www.apcoaviation.com  
7 Chalamish St., Ind. Park Caesarea, 3088900 ISRAEL





## CONTENTS:

1	DISCLAIMER OF LIABILITY	3
2	INTRODUCTION	4
3	TECHNICAL DATA	5
4	CONSTRUCTION, MATERIALS and ASSEMBLY	6
5	FLEXON® Batten system:	6
6	TRIMMING	6
7	TRIKE / FRAME	7
8	EMERGENCY PARACHUTE	7
9	SPEED SYSTEM	8
10	RISERS	8
11	TRIMMERS	9
12	A-ASSIST SYSTEM	10
13	HIT VALVES (High-speed In-Take)	11
14	INSPECTION	11
15	BEFORE THE FIRST FLIGHT	14
16	FLYING	15
17	PACKING	25
18	MAINTENANCE & CLEANING	25
19	BUTT HOLE II (Auto Debris release valves)	26
20	STORAGE	26
21	DAMAGE	26
22	THREE YEAR WARRANTY	26
23	GENERAL ADVICE	28
24	F3Bi - 36 - SKETCHES	29





### **WARNING**

This is not a training manual. It is extremely dangerous to yourself and others to attempt to fly this or any paraglider without first completing a flying course given by a qualified instructor.

Apco Aviation's gliders are carefully manufactured and inspected by the factory. Please use the glider only as described in this manual. Do not make any changes to the glider.

**AS WITH ANY SPORT - WITHOUT TAKING THE APPROPRIATE PRECAUTIONS, PARAGLIDING CAN BE DANGEROUS.**

## **1 DISCLAIMER OF LIABILITY**

Taking into consideration the inherent risk in paragliding or hang gliding, (free flying and motorized), it must be expressly understood that the manufacturer and seller do not assume any responsibility for accidents, losses and direct or indirect damage following the use or misuse of this product.

APCO Aviation Ltd. is engaged in the manufacture and sale of hang gliding, paragliding, motorized Para/hang gliding and emergency parachute equipment.

This equipment should be used under proper conditions and after proper instruction from a qualified instructor. APCO Aviation Ltd. has no control over the use of this equipment and a person using this equipment assumes all risks of damage or injury.

APCO Aviation Ltd. disclaims any liability or responsibility for injuries or damages resulting from the use of this equipment. The glider is designed to perform in the frame of the required class as certified.



## 2 INTRODUCTION

Following in the footsteps of F3 – the F3Bi is the Real Thing, for Real World Trike Pilots, **with passengers**.

Designed with solo and Tandem Trike use in mind, but also possible to foot launch\*. The F3Bi is based on the F3, which in turn is a relaxed version of our flagship F1 solo paramotor wing, bringing exceptional launch, handling and performance in an easy, comfortable and safe package to Tandem Trike pilots, coming in, in a performance class above the Lift EU, but in the same class as far as piloting and safety is concerned. The F3Bi will be enjoyed by pilots who long for the ease of use of solo wings and advanced pilots, will not be disappointed with the class leading performance and handling. Exceptionally easy launch and landing makes this the perfect wing for almost any qualified pilot looking for something more than what the LIFT series offered.

As with the F1 and F3, incorporated into the F3Bi is our Flow Aligned Ribs (FAR) feature, morphing direction from centre to tip, it aligns the ribs with the natural direction of the flow, increasing both performance and stability throughout the speed range. The roll stability of the F3 is especially impressive, allowing for agile, precise handling and dead centre landings on the threshold every time.

The canopy incorporates 2 functional “3D cuts” for the best possible leading edge shape definition.

The canopy sail tension has been optimised so that the wing becomes a homogeneous unit, solid and reassuring in flight, and resulting in our cleanest wing yet!

The riser / speed system / trim system was re-designed specifically for trike use, incorporating Apco’s ground breaking riser technologies, and has a greater usable range than any tandem wing we have built before. The extensive speed range means you can launch and land at reasonable speeds, but can accelerate with comfort (speeds of up to 80 [km/hour])\*\*, on that perfect long distance XC flight you’ve been dreaming about doing with your partner.

With the trimmers closed, the F3Bi will thermal well, and has exceptional glide ratio (for a full reflex profile wing), so if you like to mix it up on a good day, idle or cut the motor and crank it up to cloudbase with ease.

Open the trimmers and enjoy a significant speed increase of approx. 10 [km/h] (without the use of the speed bar).

If your trike has the option to use a speed bar, you will be able to use maximum speed with the comfort of being able to come back to trim speed with ease, without taking your hands off the brakes or tip steering.

Construction – weight was saved wherever possible, bringing the weight down to 8.3 [kg], while retaining APCO’s legendary durability. The low canopy mass, allows surprisingly easy inflation, especially in nil wind take-offs.

Positioned as the highest performing Reflex Tandem wing in our (and any other companies) range, it will easily satisfy every pilot graduating from a wing such as the LIFT or Hybrid Tandem, all the way up to competition pilots.





### 3 TECHNICAL DATA

<b>F3 / Size</b>	<b>36</b>
Code	22336
Cells	58
Area [m <sup>2</sup> ]	36.0
Area (projected) [m <sup>2</sup> ]	30.46
Span (incl. Stabilizer) [m]	14.7
Span (projected) [m]	11.64
Aspect Ratio	6.0
Aspect Ratio (projected)	4.45
Weight Range (all up) Para-Trike [kg]	Up to 450
Canopy Weight [kg]	8.3
Root Cord m	2.96
Tip Chord [m]	0.3
Length of Lines on B [m]	8.89
Total Length of Lines [m]	448
Frame hook-up Width [mm]	500 – 650
<b>Performance</b>	<b>Km/h</b>
V-min (at optimal wing loading) * [km/h]	25
V-trim (closed) [km/h]	36 - 40
V-trim (neutral) [km/h]	43 - 47
V-trim (open) [km/h]	50 - 56
V-max [km/h]	69
Min Sink [m/s] at optimal wing loading	1.2 m/sec

\*All Data measured at sea level, using a combination of GPS and Speed Probe, averaged over several runs.  
It is important to note that many factors will influence measured performance data, including;  
wing loading, frame configuration, temperature, humidity, and height above sea level.





## 4 CONSTRUCTION, MATERIALS and ASSEMBLY

The glider is constructed with a top and bottom surface, connected by ribs. One top and bottom panel, together with the connecting ribs is called a cell. Each cell has an opening on the front lower part. The cells fill with air forcing the panels to take the shape dictated by the air-foil (rib) section. On either side the wing ends in a stabilizer or wing tip, which provides straight-line (Yaw) stability and produces some outward lift to keep the span-wise tension.

The front part of the ribs utilise APCO's FLEXON batten system to keep the leading edge shaped at high speeds and in turbulent air. They also improve the performance and the launch characteristics of the glider.

The line hook-up points are made of Dyneema and imbedded in the bottom surface of the wing for minimal drag and maximum performance.

The glider is made from tear resistant Ripstop Nylon cloth, which is P.U. coated to zero porosity and then siliconized to give the fabric high resistance to the elements. Different cloth is used for the top, bottom and ribs due to their different functions.

The lines are made of superaramide covered with a polyester sheath for protection against UV, wear and abrasion.

The bottom section of the brake lines is made of polyester because of its better mechanical properties.

The maillon quick links that attach the lines to the risers are made of stainless steel.

## 5 FLEXON® Batten system:

New generation FLEXON ® batten system incorporated (see below) in the leading edge of the ribs, insuring perfect profile shape (instead of traditional Mylar reinforcement). FLEXON ® battens reduce the weight of the glider by an additional 500gr. and unlike Mylar reinforcement will guarantee no deterioration in performance or launch.

Additional advantage of FLEXON batten is that it is practically indestructible, safeguarding the performance and launch over the lifespan of the glider.

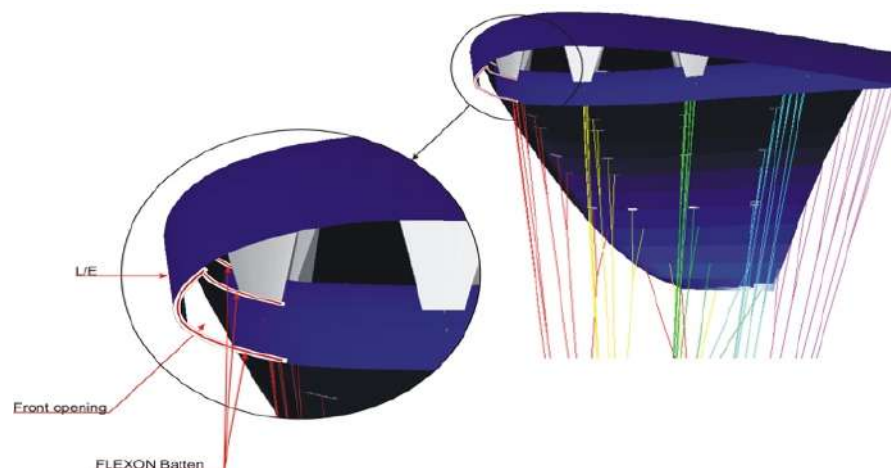

## 6 TRIMMING

All Apco wings are trimmed for optimum performance combined with unsurpassed safety. It is very important not to re-trim or tamper with any of the lines or risers as this may alter the performance and safety. Trimming of the brake line should be done in accordance with this manual and carefully checked before flying.



## 7 TRIKE / FRAME

The F3Bi is designed for European style trikes, with a frame / riser attachment width of 500 – 650mm only.

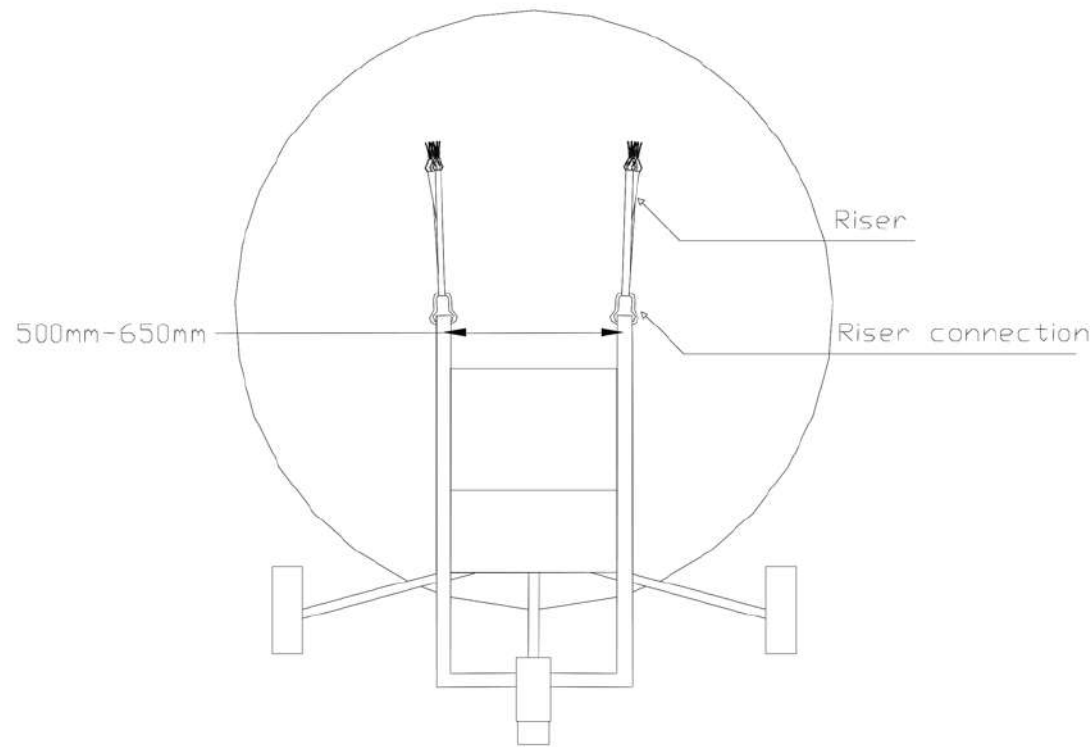

## 8 EMERGENCY PARACHUTE

It is recommended to use a certified rescue parachute when flying, no matter your intended altitude or flying style. Attaching the rescue parachute should be done in accordance with the recommendations of the trike manufacturer and reserve parachute manufacturer. When we fly the F3Bi, we use the the Apco Trike Pilot and Trike Passenger harnesses, combined with Mayday UL28 Parachute, packed in the matching reserve container. Always check the reserve handle and locking pins during every pre-flight check.



## 9 SPEED SYSTEM

Certain Trike manufacturers give the option to use a speed-system acting on the front of the risers to accelerate the wing, which may be used in conjunction with the trim system. We have designed the F3Bi risers with this in mind.

### ASSEMBLY & ADJUSTMENT

Before the first flight, it is imperative to make sure that the speed system will not be applied due to being adjusted too short. We recommend following the trike manufacturer's instructions for adjustment.

**WARNING:**  
 The use of the speed system in turbulent conditions or close to the ground is dangerous. While flying with the accelerator, the wing has a reduced angle of attack and is therefore more susceptible to turbulence and may collapse or partially deflate. Gliders react faster when accelerated and may turn more. The accelerator should immediately be released in this case.

## 10 RISERS

The F3Bi is supplied with risers featuring a split A riser. The 1st A-riser attaches to the central three A lines (A1, A3 & A5). The second A-riser is attached to the outermost A line (A7). At no time should the pilot change the risers or use risers not intended for this specific glider as this will affect the performance and safety of the glider.

The riser is equipped with both an accelerator and trimmers.

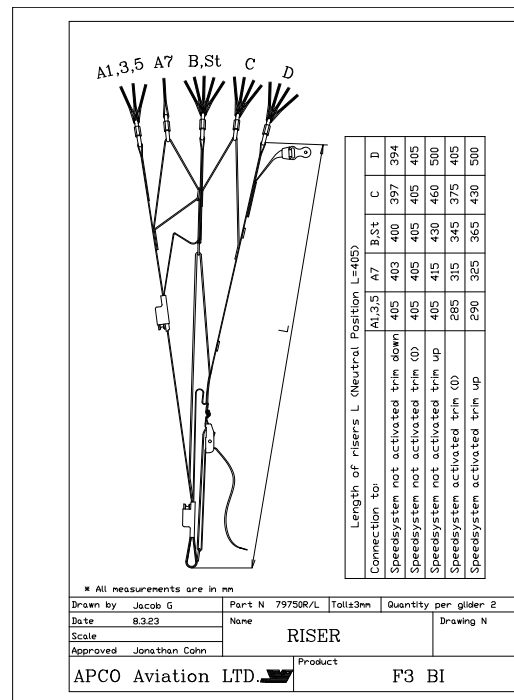





## Replaceable trimmer system

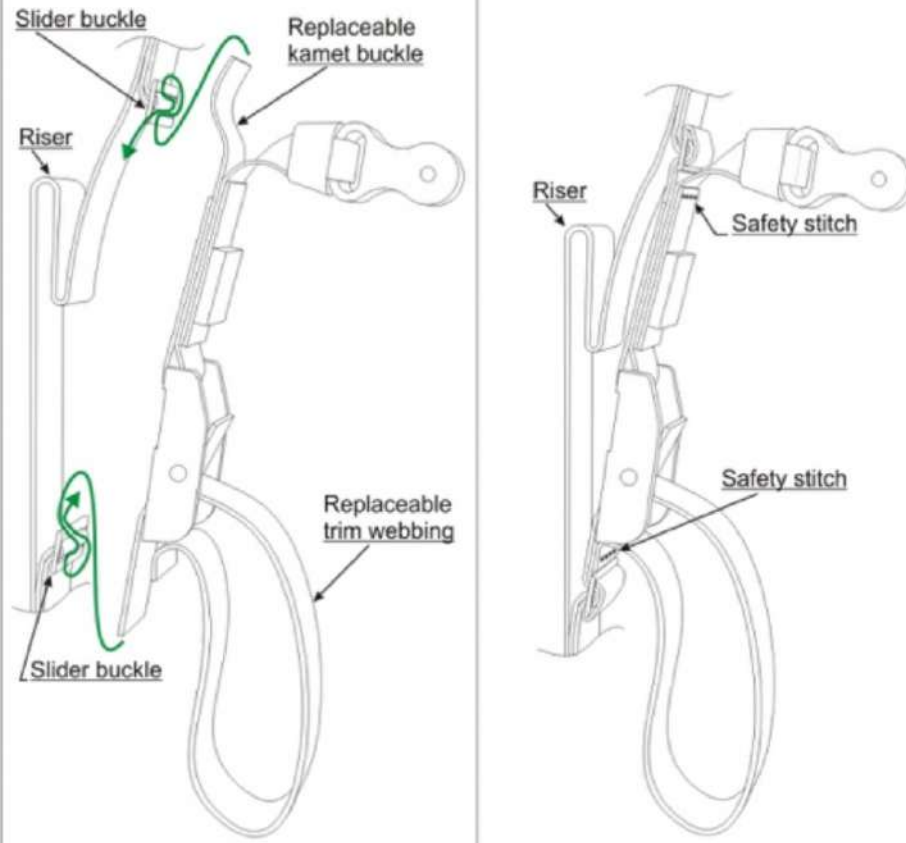

1. Undo the safety stitch of kamet or trim webbing, depending on what requires replacement.
2. Take out the kamet or trim webbing requiring replacement, by removing it from the slider buckle.
3. Replace trim webbing or kamet with new by guiding it back through the slider buckle, verify the trim range is unchanged, on trim speed all the riser branches are at equal height. When kamet fully released it should not retain any load (all the load is on the fully released D branch of the riser).
4. Restitch the safety stitch to lock the configuration of the trim in place.

## 11 TRIMMERS

The F3Bi risers were specifically developed for Trike use, and are equipped with trimmers which are replaceable should they wear out.

The neutral setting is when the A/B/C/D riser legs are of equal length in flight (blue mark on the trim webbing).

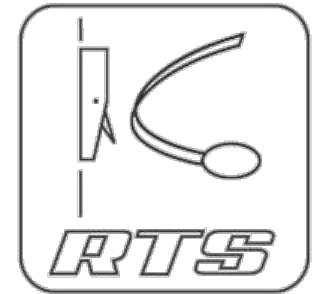

For take-off and landing, the trimmers should be in the neutral position. After take-off set them according to your needs and the conditions, and close them again before landing. They can also be set asymmetrically to compensate for torque effect. The Trim System of the F3Bi is very effective for accelerating the wing on long flights. The trim system differs from previous Apco gliders in that it releases the B riser, which gives a clean rotation of the profile, and is very efficient.



## 12 A-ASSIST SYSTEM

The A-Assist system may improve launch characteristics if needed, it may be especially useful with weaker trikes. The system works by decreasing the angle of attack while the wing is behind the trike, and gradually disengages as the wing rises overhead. This is done by attaching a line from the frame about 30cm in front of the riser attachment points, to the speed system on the risers.

Care must be taken that the system will be fully disengaged once the wing is overhead, and also, that it will not interfere with the speed system if used in conjunction – be sure to also refer to your Trike user manual.

### Installation and Adjustment:

Connect the risers to the trike, and set the trims to the neutral position.

Connect the A-Assist Lines to the Brummel-hooks on the risers.

While holding the risers up in the flight position, attach the A-Assist line to the frame at a point approximately 30cm in front of the riser attachment point. This distance is greater than on wings that do not have a speed system on the risers, as it is working through the reduction of the speed system. When correctly adjusted, the line will not have tension on it when in flight, but will shorten the front riser legs relative to the rear ones when the wing is behind the trike by about 8cm depending on pilot preference and power of trike etc.

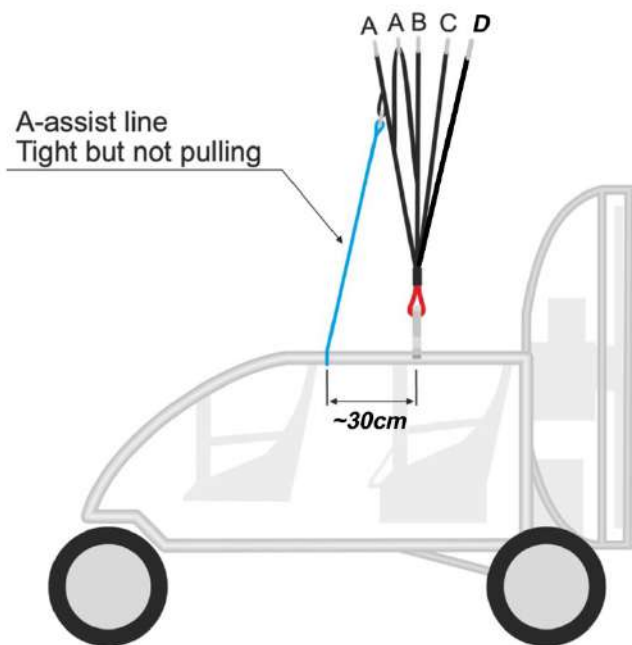

## F3Bi A-Assist

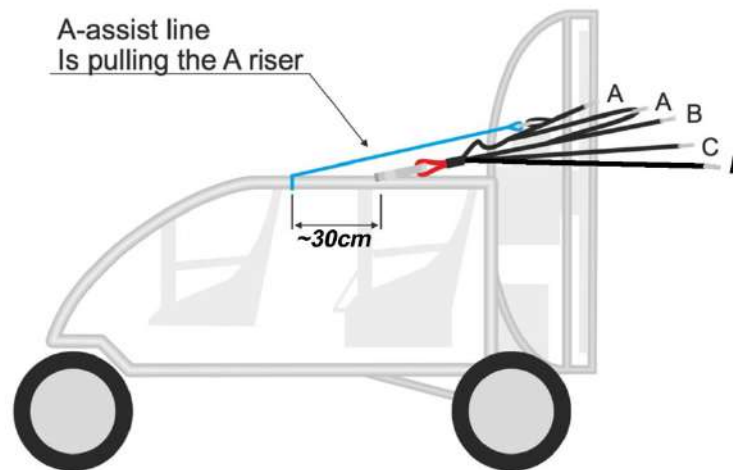



## 13 HIT VALVES (High-speed In-Take)

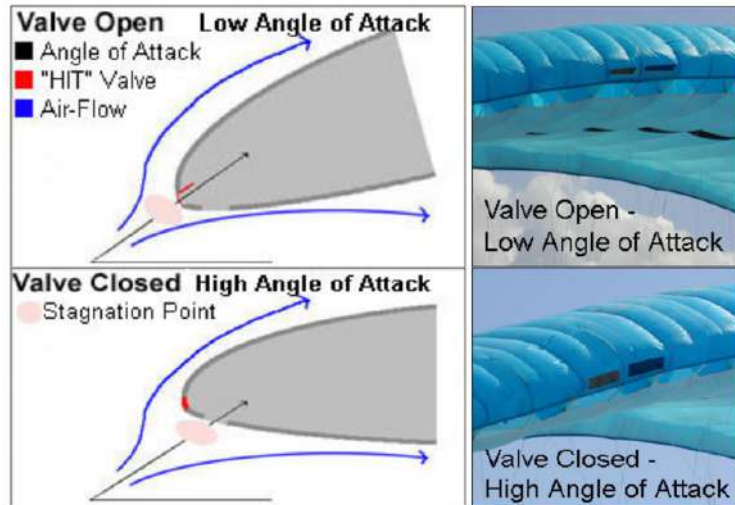

The F3 is equipped with an Active HIT Valve system (patent pending) to improve the overall performance and safety of the wing especially during accelerated flight.

The valve system allows maximum inflow of air when the glider acquires a lower angle of attack while accelerated. HIT valves open and close in flight to increase the internal pressure of the glider.

For the valves to work properly it is important to keep them wrinkle free especially in sub zero temperatures. Make sure the valves are lying flat and are in the closed position when you fold the glider. Before launch the pilot should check all the valves and verify that they are flat and cover the entire area of the mesh opening. Creased and wrinkled valves will not adversely affect the safety of the wing.



## 14 INSPECTION

### GENERAL

Pilots, please ensure that your glider has been test flown and fully checked by your dealer before taking it into your possession. Verify that the dealer checked and confirms that the glider is airworthy.

In case of use of the wing in combination with trike:

Due to the very wide assortment of trikes on the market with different set up and design, it is necessary to verify that the specific trike can be successfully coupled with the wing.

Please make sure your dealer performs the following procedures before first flight:

A. It was checked with APCO that the specific trike can be flown with your new wing.

In case the specific combination is not checked by APCO – your dealer must take the following necessary steps :

B. Wing to be fully inspected by the dealer as in the paragraph above

C. Wing to be ground handled and visually checked while inflated.

D. Connection method to the trike is in line with APCO's recommendation according to the sketch below. Pilot can reach both main brake handles and tip steering handles (if available).

E. Before first take-off perform "taxiing" test on the ground slowly rolling with the wing checking all aspects of the set-up without actually taking off. (Including roll/yaw stability, pitch stability, stall tendency, brake response etc.)



- F. Only once the wing passes the taxiing test – then the next step is to make the actual test flight to make sure trike and wing are correctly coupled and the system is airworthy.
- G. Take the wing into your possession only after your dealer confirms that wing is airworthy when coupled with your trike.

### **ANNUAL / PERIODICAL AIRWORTHINESS INSPECTION**

It is highly recommended that your glider (and other equipment), undergo a Periodical Airworthiness Inspection which is to be done by Apco, or an Apco approved / appointed service centre.

This is recommended to be done every 24 months or every 100 hours, whichever comes first.

This recommendation is in line with Israeli regulations, binding in Israel. as an alternative, we suggest for you to follow the regulations set by your national authorities.

### **POROSITY:**

Porosity is measured with a calibrated Porosimeter. It should be measured in at least 5 different places on the upper surface. Below is an example of the sections we test at Apco. The upper surface, at 20-35% chord (from L/E) is most prone to becoming porous, and is thus the most important section to test. It is also important to test the different cloth types, and different colours used.

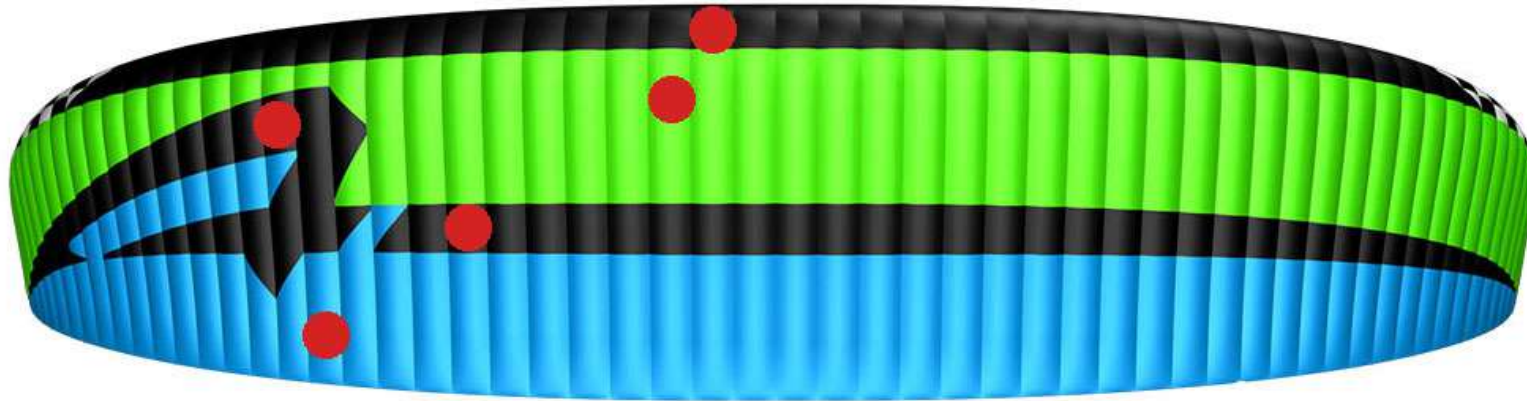



## LINE MAINTENANCE

Superaramide lines are known to be sensitive to the influence of the elements. They must be carefully inspected periodically. In his/her own interest, the pilot must observe the following points to ensure maximum performance and safety from the glider. Avoid sharp bending and squeezing of lines. Take care that people do not step on the lines. Do not pull on the lines if they are caught on rocks or vegetation. Avoid getting the lines wet. If they do get wet, dry them as soon as possible at room temperature and never store them wet.

One line of each line group (a, b, c, upper and lower) must be tested for minimum 50% of the rated strength. if the line fails under the load test or does not return to its specified length all the corresponding lines must be replaced. never replace lines with different diameter or type of lines as all gliders were flight and load tested for safety in their original configuration. Changing line diameter/strengths can have dangerous / fatal consequences.

Professional use of gliders: towing, tandem, schooling and competition flying requires more frequent line inspection and replacement of A, B, C, D and brake lines. [For replacement lines please refer to our online direct line services.](#)

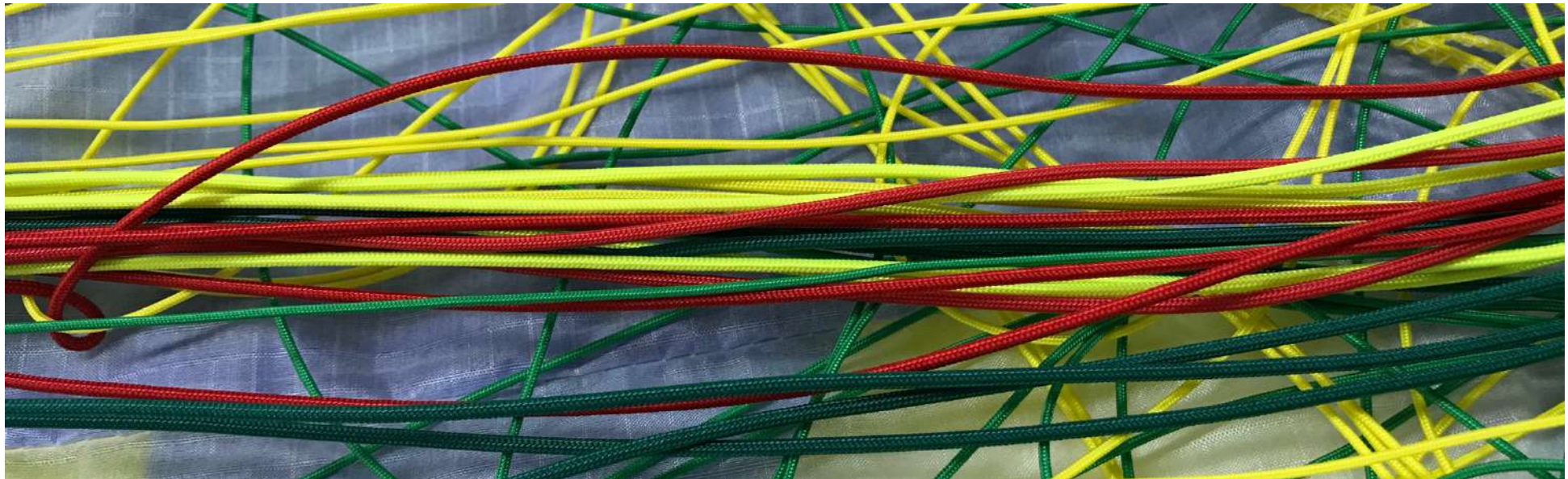



## 15 BEFORE THE FIRST FLIGHT

### BRAKE SETTING



(Sample Riser for Illustration purposes only)

Before the first flight the pilot / dealer has to inflate the glider in the flight configuration, on the intended trike frame, to check and if needed, adjust the brake line length as required. It is important that the brakes are not set too short. With the wing overhead, the brakes should have at least 10 cm of free travel in the brake line from the brake guide on the riser to the activation point of the brakes (See Diagram). If the pilot changes the type of paramotor, please check the brakes again to ensure that the brakes are not too short.

Since there are several hook-up point configurations on paramotors, the F3 comes with longer brake lines to allow for adjustment to your requirements, however, this should only involve lengthening **not shortening**. Shortening the brakes will cause them to be too short when accelerating the wing, which can be both dangerous, and inefficient. The excess lines should be trimmed or taped or stowed in a safe manner so that they do not increase the chance of the brakes getting pulled through the mesh into the propeller.

### TIP STEERING

The Factory setting of the Tip Steering line should satisfy most pilots. The tip steering line and magnet is placed very specifically on the riser, and a point which will not change with different trim and accelerator positions.

If you shorten the tip steering line, make sure that it is not over tensioned in any of the speed configurations.

If you extend the Tip Steering lines, make sure that they are not too loose in flight, which may result in them being caught in the propeller.



## FIRST CHECK AND PREFLIGHT INSPECTION

With every new glider, the following points should be checked:

- Connection points between the glider and the harness.
- Check that there are no lines twisted, tangled or knotted.
- Check that the risers and speed-system are hooked up to the harness correctly.
- Check that the trimmers are set to the neutral position or below.
- Motor related checks to be done in accordance with motor manufacturers manual.
- Harness related checks to be done in accordance with harness manufacturers manual.

## REGULAR INSPECTION CHECKS

- Damage to lines, webbing and thread on the stitching of the harness and risers.
- The stainless-steel connection links on the risers are not damaged and are fully closed.
- The pulleys of the speed system are free to move and the lines are not twisted.
- The condition of the brake lines, stainless steel rings and the security of the knot attaching the brake handle to the brake line.
- The sewing and connection of the lines.
- Damage to hook up points on the glider.
- Internal damage to the ribs and diagonal ribs.
- Damage to the top and bottom panels and seams between panels.

### NOTE:

Before each flight, it is essential to perform a complete check of the all your equipment, including the wing, harnesses, frame, reserve parachute and engine.

## 16 FLYING

### TIPS

- Never position the Trike / Motor downwind of the wing.
- Double check that there is no fuel leakage.
- Do you have enough fuel for the flight? It is always better to have too much than too little!
- Check that there is nothing loose in the harness that could possibly contact the propeller in flight.
- Whenever you encounter a problem, fix it **AT ONCE** however small it is!
- Always put on and lock your helmet before getting in the harness.
- Before each launch do a full pre-flight inspection.

In powered flight most of the wing characteristics remain as described above (Chapter 16). Still there is additional information needed, concerning power output, proper matching of the wing/engine/propeller etc. APCO can try to give advice on some possible tested combinations, but if you contact your nearest APCO dealer or frame manufacturer they will always be ready to help.



## FIRST FLIGHTS

In order to get familiar with your wing we recommend flying with trimmers at the 0 position first in stable non-turbulent weather. Once you feel confident with your wing, you can start experimenting with faster trim settings and speed system, taking all necessary precautions. Learn to use all of the additional speed of the F3.

**Remember:** do not exceed the envelope of weather, wing and other parameters to insure safe flying.

## INFLATION

Check wind direction, even when it seems that there is no wind at all, there is always some drift. Therefore, be careful in determining the conditions, since in PPG flying it is most important that the launch and initial climb are performed with a head wind (the danger of losing your airspeed while crossing the wind gradient is greatly reduced). Special attention must be paid to trees, power lines and other obstacles, including the possibility of emerging rotors.

### Launch preparation

Lay out the paraglider in an arc, downwind of the power unit, with all suspension lines taut and pointing toward center of the power unit. The risers are to be laid on the ground.

Set the trimmers in 0 positions.

Make sure that you warm up the engine while standing windward of the wing. Stop the engine before clipping in the risers.

### Now have quick checks if:

- Helmet is on and fastened.
- The risers are clipped into the carabiners.
- The trimmers are properly set.
- Propeller is clear.
- Speed system is functioning, problem free.
- Steering lines and handles are free and not twisted.
- The engine delivers full power.
- Take off area is clear of approaching traffic, obstacles and free to use.

When you are sure all is OK, you can clip in the wing and execute launch as described in paragraph 17.2.

From now on you should steer / handle the paraglider facing forward, without looking back over your shoulder. If the wing is retreating and behind you at a low angle, do not turn around as there is a danger of falling on your back and damaging the propeller and catching lines in the propeller, so it should be avoided.

During take-off, when you feel the tension on both risers to be equal, make sure the wing is overhead, open up full power and lean back





to counter the engine thrust, so that it can push you forward rather than towards the ground.

The best option is not to use the brakes, allowing the paraglider to rise as it was laid out.

If it starts to deviate from its course, pull the opposite riser and run under the centre of the wing while continuing in the initial direction.

If the wind suddenly drops, give a strong pull on the risers.

If the paraglider falls to one side or back too far to lift again - kill the engine, cease launch and check the conditions once again.

As the wing rises, the forces grow lighter and it should stabilize above your head without overshooting.

This is the best moment to check if it is inflated well and the lines are not tangled, **but do not stop or turn.**

Once you feel the forces on the risers decrease, run faster and let go of the risers.

See if there is already any opposition on the brakes and, if necessary, use them to correct direction or to increase lift at take-off.

### **Remember:**

- If the cage of your power unit is not stiff enough, the risers will strain during launch and can deform it to the extent of collision with the propeller. Before applying full throttle, see that the cage does not catch any lines.
- Any brake operation (or steering input in general) should be smooth and gentle.
- Do not try to take off until you have your wing overhead. Hitting power before that can cause dangerous oscillations.
- Do not sit in the harness until you are sure you are flying!
- The faster the trim setting is, the more brake input is required to take off. The F3 is best with trims fully closed for takeoff and landing

### **CLIMBING**

Once you are safely airborne, continue heading against the wind, using brakes to correct the direction.

#### **Do not try to climb too steeply.**

In powered flight the F3 behaves more like an airplane than a paraglider, and it is good idea to regard it as such. If there are no obstacles present, it is by far safer to fly level for a while after take-off, clearing the ground gradually, gaining some speed before converting it to height with a light application of the brakes.

Another reason not to try climbing too steeply is the risk connected with engine failure at low altitude.

F3 in a steep climb does not stay behind as much as conventional paragliders.

The F3 does not have SRS (prevents or delays possible stall), so low speed at low altitude carries inherent danger of stalling



Besides, you should always be able to land safely in case of engine malfunction, so it's better not to take unnecessary risk and always fly with a safe margin of speed and height

Depending on the power unit geometry, it is possible that after take-off you will notice a propeller torque (known as P-factor), which may induce a turn, which increases with the amount of power, this can be countered with steering, and asymmetric trimmer settings. When climbing steeply with closed trimmers and high power, beware of the possibility of stall – avoid using deep brakes in this attitude. Due to considerable vertical distance between thrust axis and wing chord - the range of safe power operation is closely connected to your skills and equipment.

Power-unit induced oscillations:

Certain configurations of engine weight, output and propeller diameter can cause roll oscillations, during which the pilot is being lifted to one side by the torque effect, swings down due to his weight, and then is lifted again and so on.

**To avoid this, you can:**

- Change the amount of throttle,
- Adjust the cross bracing to counteract the torque (if present),
- Shift yourself to the other side of the harness and/or
- Change the trimmer setting.

The best method is to apply some weight-shift.

Such oscillations usually occur at high power - the greater the engine output and propeller diameter, the bigger the swings.

In addition, pilot reactions can often be wrong or come too late, increasing the problem instead of solving it.

In this case the safest way to deal with this question is to close the throttle and release the brakes.

Less-experienced pilots especially tend to overreact.

This is called a pilot-induced oscillation, and the proven solution is to **leave the brakes alone**.

## LEVEL FLIGHT

If you have a vario meter or altimeter – check it regularly.

In level flight it is very easy to start climbing unintentionally.

The instrument will help you optimize speed and fuel economy.

Every flight is affected by the configuration of your gear, but due to F3's ability to fly safely without constant piloting, it will let you adjust everything to the best effect.

Good knowledge of weather conditions (e.g. wind at different altitudes) and knowledgeable use of thermals, convergence or other kinds of lift will help you greatly reduce fuel consumption and increase flight range.

Do not hesitate to thermal with the F3 in order to win some altitude and spare fuel - you will be surprised how efficient it is.

Closing the trimmers will make the climb ratio even better.



## TRIMMERS AND SPEED-SYSTEM SETTINGS

You are free to experiment with all possible settings, **as long as you are at safe altitude and watch the weather**. Fully opened trimmers increase the speed of the wing and overall penetration and reflex, **but when trimmers are opened it is highly recommended to use secondary steering only (stabilo steering), using the main brake handles will increase the risk of a collapse.**

As forces on the brakes grow at high speeds, weight shift or steering with STABILO STEERING system becomes increasingly effective. **The TIP STEERING system can be used in all trimmer and speed system positions, also in combination with main brake handles.** At maximum speed bar and fully opened trimmers we **highly recommend** steering with STABILO STEERING system. Strength needed to initiate the turn will be smaller and there will be no decrease in speed.

On the other hand, slow trimmer settings decreases sink and steering forces, so it is possible to efficiently use the thermals. Worth noting is the F3's impressive speed range -the maximum speed is more than double the stall speed.

Turns can be much improved by additional use of throttle, speed-system etc. Once you master these techniques, you will be able to execute fully coordinated and effective turns.

### REMEMBER:

Trim setting must be part of the pre-start check list!  
Taking off with open trims may be dangerous.  
Asymmetric adjustment will have an inherent turn.

## LANDING

In PPG flying there are two kinds of landing: with and without power:

### POWER OFF LANDING

At an altitude of 50 meters switch the engine off and glide as you would on a conventional paraglider. It reduces the chances of damaging the propeller on landing, but on the other hand there is only one attempt possible -so it has to be done right!

F3 preserves the energy well, so there is a long float necessary, exchanging the abundant speed for lift with your brakes.

### POWERED LANDING

Make a flat approach with the engine idling, then level out and lose the speed before final flare. **Immediately on landing, switch off the engine.**



The main advantage of this procedure is of course the possibility of going around with the wing again (repeating the approach) if anything goes wrong.

Still, if you forget to switch off the ignition before the wing falls down, there is a considerable risk of damaging propeller, catching lines in it or even suffering injuries connected with falling on your running engine.

**Remember:**

- Whenever possible, get to know the landing field before taking off.
- Check the wind direction before planning the approach.
- Landing with power off requires much less space.
- In case of any doubt, practice the landing until you feel totally safe
- After landing, continue to maintain the wing's direction straight, as on turning you always risk getting lines in the propeller.
- Turn only if there is danger.

**Brake Operation (2D)**



Two Dimensional brake configuration

Two dimensional brake arrangement combines the main steering with the tip steering. It takes a little while to get used to this system, but it allows multiple options of steering and is very intuitive.

The pictures below present the two extremes but all the range in between is possible.

When the hands are stretched to the sides, all of the trailing edge is pulled down.  
Is intended for unaccelerated maneuvering only.

All of the trailing edge is pulled

The hands are stretched to the sides



When the hands are near the body only the tips are pulled down.  
Is intended primarily for accelerated maneuvering.

Only the tips are pulled

The hands are near the body





## FLYING SPEED

Indicated trim speed is dependent on the amount of brake the pilot is using, wing loading, altitude above sea level and the accuracy and make of speed probe. The speeds recorded in technical data were at optimum wing loading at sea level using a Flytec, 6030 thus there could be a slight variation in speed range numbers that a pilot may record.

Speed readings in the flight reports could differ as this was measured during testing using various instruments and is an indication of the difference between trim, stall and top speed. The speed range will be the same but the actual numbers may differ.

- With 0% brake and trimmers at 0 (Neutral) the F3 will fly at 45 - 49 km/h with a sink rate of 1.5m/s.
- Trim closed, and 25% brake the glider will fly at 35-39km/h with minimum sink rate 1.2 m/s.
- The best glide angle is achieved with closed trims 0% brakes applied.
- At 80% of the brake range, the glider will fly at about 28km/h and will be close to the stall point at about 26km/h (at optimum weight).

### **CAUTION:**

APART FROM WHEN FLARING AT LANDING THERE SHOULD BE NO REASON TO FLY WITH 70% TO 100% BRAKE. THE SINK RATE OF THE GLIDER WILL BE EXCESSIVE AND THERE WILL BE A POSSIBILITY OF ENTERING A DEEP STALL OR FULL STALL SITUATION. THERE IS ALSO THE RISK OF GOING NEGATIVE OR ENTERING A SPIN WHEN ATTEMPTING TO TURN THE GLIDER NEAR THE STALL SPEED.

### **WARNING:**

The use of the speed system in turbulent conditions or close to the ground is dangerous. While flying with the accelerator, the glider has a reduced angle of attack and is therefore more susceptible to turbulence and may collapse or partially deflate. Gliders react faster when accelerated and may turn more. The accelerator should immediately be released in this case.

## THERMAL FLYING

F3 has high internal pressure and needs very little pilot input even in very turbulent conditions.

In light lift it is advised to make flat turns to keep the glider from banking too much and avoid increasing the sink rate.

In strong lift conditions it is most effective to make small turns in the core with relatively high bank.

For the best climb rate in ridge lift we recommend using about 15% to 20% brake and **trimmers fully closed**.

## ASYMMETRIC COLLAPSE

If one side of the glider partially folds or collapses it is important to keep your flying direction by applying weight shift and some brake on the opposite side.

The wing should re-inflate on its own without any input from the pilot.



To help re-inflation it is possible to pull some brake on the collapsed side and release immediately.

In the event of a big deflation, i.e. 70%, it is important to apply brake on the inflated side of the wing, but care must be taken not to pull too much as you could stall the flying side.

The glider is very solid and has a strong tendency to re-inflate after collapse.

## **CRAVAT**

In case a cravat should occur from an asymmetric collapse or other manoeuvres, it is important to keep your flying direction by applying some brake on the opposite side and then it can usually be opened by pulling down on the stabilo line of the affected side while countering the turn with the opposite brake and weight shift.

## **FRONT STALL OR SYMMETRIC COLLAPSE**

In the event of a front stall the glider will normally re-inflate on its own immediately without any change of direction. To speed up re-inflation briefly apply 30%-40% brake (to pump open the leading edge). **Do not hold the brakes down** permanently to avoid an unwanted stall.

## **B-STALL**

The F3 has a very clean, stable B stall.

To enter the B stall the pilot has to pull the first 20-cm slowly until the glider loses forward speed and starts to descend vertically.

Then the pilot can pull more on the B until he/she attains a stable 7 to 9 m/s descent rate. The Glider has no tendency to front rosette or become pitch unstable. To exit the B stall the pilot releases the B slowly until the glider has regained its shape and then the **last 15 cm fast** to prevent the glider from entering deep stall.

The F3 can be controlled directionally in the B stall by pulling more on one B riser than on the other to create a turn in any direction. The B-stall is a safe controlled way of losing altitude fast without any forward speed.

## **BIG EARS**

Big ears are possible on the F3, and can be an effective descent method.

This should only be done with the trimmers in the closed to neutral range.

Big ears are induced by pulling the outer A-Lines, which are on their own riser leg, making it simple to identify and induce.

## **DEEP STALL (Parachutal Stall)**

Under normal flying conditions the F3 will have no tendency to enter deep stall. All gliders can however under certain conditions enter and stay in deep stall configuration (as a result of ageing of materials, improper maintenance or pilot induced).



## Signs of parachutal stall

- The pilot has very little or no forward airspeed and no wind in his face.
- The glider will be fully open but the cells will be bulging in and not out on the bottom surface.
- The glider might have a very slow turning sensation.
- You will have an increased vertical descent.

## Recovery from parachutal stall

It is important to recognize this situation. Most accidents involving parachutal stall happen because the pilot did not realize that he was in deep stall.

The best way to exit a parachutal stall is to pull all the A risers down to get the wing flying again. The pilot can pull the riser down until the wing starts to fly again. The moment the wing starts to fly the pilot should release the A risers, or the wing might suffer a frontal collapse.

Alternatively, the pilot can push the speed bar to lower the angle of attack and get the wing flying again.

By pulling one or both brakes while in deep stall the pilot can accidentally enter a full stall or spin. (Not recommended)

## SPIRAL DIVES

The F3 has very good behaviour in spiral and has no tendency to stick in the spiral. By progressively applying brake on one side the glider can be put into a spiral dive. Safe high sink rates can be achieved like this. The spiral has to be exited slowly by releasing the brake over one complete turn or the glider may pitch forward and possibly suffer a collapse.

**Care must be taken that the pilot has enough height to exit the spiral safely.**

**Sink rates in excess of 19m/s can be obtained.**

### **CAUTION:**

SOME GLIDERS CAN BE NEUTRAL IN SPIRAL AND MAY NOT EXIT WITHOUT PILOT INPUT. TO EXIT A NEUTRAL SPIRAL THE PILOT HAS TO LEAN HIS/HER WEIGHT TO THE OUTSIDE OF THE TURN OR APPLY BRAKE INPUT TO TURN OUT OF THE SPIRAL (ON THE OUTSIDE WING). AS SOON AS THE GLIDER STARTS TO SLOW DOWN IN THE SPIRAL THE OUTSIDE BRAKE MUST BE RELEASED.

PILOTS CAN SUFFER BLACK OUTS IN SPIRALS AND THE PILOT HAS TO EXIT THE SPIRAL AS SOON AS he/she FEELS ANY ABNORMAL SYMPTOMS (Black dots in field of vision or light-headedness).

## STRONG TURBULENCE

Firstly, if you know its turbulent conditions – DON'T TAKE OFF!!!



If you unexpectedly encounter strong turbulence, fly with **trimmers open and no brakes applied** to let the reflex stabilize the glider, use only secondary brake handles (tip steering) and land as soon as possible.

## **STEERING NOT FUNCTIONING**

If the pilot cannot reach the brake or steering lines for any reason or if they are not functioning properly, (for example: If they break on a damaged point) the pilot can control the glider by pulling down on the rear risers, and depending on the harness / frame-type and configuration, also by using weight shift.

Care must be taken when steering like this, as much less input is needed to turn the wing and the response of the wing is also much slower than when using the brakes.

If you pull too much on one or both risers the glider will spin or stall.

On the landing flare the pilot should be especially careful not to stall the glider too high.

## **LANDING**

Before landing, the pilot should determine the wind direction, usually by checking a windsock, flags, smoke or your drift over the ground while doing one or more 360° turns.

- Always land into the wind.
- At a height of about 50 meters your landing setup should begin. The most commonly used one is to head into the wind and depending on the wind strength the pilot should reach his/her landing point by making s-turns.
- At a height of about 15 meters the final part of your descent should be made at trim speed into the wind.
- At a height between half a meter and one meter you can gently flare the glider by pulling gradually down on the brakes to the stall point. When top-landing it is sometimes not necessary to flare or a much smaller flare may be required, especially in strong ridge conditions.

## **TREE LANDING**

If it is not possible to land in an open area, steer into the wind towards an unobstructed tree and do a normal landing approach as if the tree is your landing spot. Flare as for a normal landing. On impact hold your legs together and protect your face with your arms.

After any tree landing it is very important to check all the lines, line measurements, and the canopy for damage.





## WATER LANDING

As you approach landing, open all the buckles of the harness except for one leg. Just before landing, release the remaining buckle. Let the wing pitch completely forward until it hits the water with the leading edge openings; the air inside will then be trapped, forming a big air mattress and giving the pilot more time to escape. Less water will enter the canopy this way, making the recovery much easier. **Get away from the glider and lines as soon as possible**, to avoid entanglement. Remember that a ballast bag can be emptied and then inflated with air for a flotation aid.

The wing should be carefully inspected after a water landing, since it is very easy to cause internal damage to the ribs if the canopy is lifted while containing water. Always lift the canopy by the trailing edge, not by the lines or top or bottom surface fabric.

## 17 PACKING

Spread the wing completely out on the ground. Separate the lines to the left and the right side of the glider. If the risers are removed from the harness, join the two risers together by passing one carabiner loop through the other. This keeps them neatly together and helps to stop line tangles.

Fold the canopy alternately from the right and left sides, working towards the centre, press out the air, working from the rear towards the front. Place the risers at the trailing edge of the folded canopy and use them to finally roll up the canopy.

## 18 MAINTENANCE & CLEANING

Cleaning should be carried out with water and if necessary, gentle soap. If the glider comes in contact with salt water, clean thoroughly with fresh water. **Do not use solvents of any kind**, as this may remove the protective coatings and destroy the fabric.



## 19 BUTT HOLE II (Auto Debris release valves)



The F3 is equipped with Butt-hole II, which automatically clears smaller particles such as sand, grass and stones from the wing.



## 20 STORAGE

When the glider is not in use, the glider should be stored in a cool, dry place. A wet glider should first be dried (out of direct sunlight). Protect the glider against sunlight (UV radiation). When on the hill keep the glider covered or in the bag. Never store or transport the glider near paint, petrol or any other chemicals.

**Do not leave your paraglider in the trunk of a car or exposed to the sun.**

Temperatures on a hot summer's day in a closed environment: car, etc. can easily reach over 60°C

At these temperatures Nylon permanently changes its characteristics which may alter the behaviour and shape of the wing.

It will cause permanent damage to the paraglider, rendering it non-airworthy. APCO's warranty will not be applicable.

## 21 DAMAGE

Using spinnaker repair tape (for non-siliconized cloth) can repair tears in the wing (up to 5cm). A professional repair facility should repair greater damage.

## 22 THREE YEAR WARRANTY

The following warranty is granted by APCO Aviation Ltd. with respect to all of its standard Serial Production Wings, manufactured from January 1, 1994, subject to full compliance by the purchaser/owner to its following terms, as hereby detailed:



APCO Aviation Ltd. guarantees the fabric of its wings against porosity to the extent that the wing becomes Unairworthy. The fabric is warranted to remain sufficiently impermeable to air, to fly safely for a period of 250 hours or 3 years, whichever comes first. APCO Aviation Ltd. undertakes at its option to repair or replace the wing, as necessary, at APCO's discretion. The under-surface porosity does not affect airworthiness, and does not need to be checked during annual inspection.

This warranty is subject to the following limitations: a. The original purchaser has properly completed and returned the Warranty Registration Card to APCO Aviation Ltd. b. The wing owner duly records the wing's flight time and use, in an official Log Book, signed by himself and/or an official instructor site supervisor, meet official etc. This Warranty will not be in force for wings without properly registered and logged Flight Records. The wing has undergone its periodical inspections as required in accordance with its users' Manual and Directives of Association, to which the owner is affiliated, and has received its periodical signed Airworthiness Certificates from the owner's local paragliding authority, to this effect. d. The wing has been properly maintained and serviced, exclusively by APCO authorized dealers and their employees, and cleaned, dried, packed and stored in accordance to the manufacturer's instructions. For replacement wings the owner shall be entitled to a discount from the retail price proportionate to the remaining life span of the wing, as covered by this Warranty (pro-rata).

The wing has been flown for recreational use only – high stress applications, including (but not exclusive to) towing, instability manoeuvres, schooling, training and any professional use of the wing, are expressly excluded from the terms of this Warranty.

This warranty does not apply to the following:

- Use outside the specified load limitations.
- Colour fading of the fabric.
- Damage or corrosion caused by solvents, fuel or other chemicals.
- Accidental or flight (take off/landing) related damage.
- Damage caused by emergency parachute deployment.
- Modified wings.
- Any special, indirect, incidental or consequential damages of any nature whatsoever, resulting from the use of the wing, or lack of use and pleasure thereof, other than the cost of the product.

This warranty is transferable.

Your statutory rights are in no way affected by this warranty.

The manufacturer retains the right of final decision regarding any claims made within the framework of this warranty.



## 23 GENERAL ADVICE

A qualified person or agent of the company should check the glider every year.

The glider is carefully manufactured and checked by the factory. Never make changes to the wing or the lines. Changes can introduce dangerous flying characteristics and will not improve flying performance.

Do not put the glider in direct sunlight when not necessary. In order to protect the glider during transportation or waiting time we recommend one of our lightweight storage bags.

- Do not fly over water, between trees or power lines and other places where engine failure will leave you helpless, always make sure you have possibility for emergency landing.
- Mind the turbulence caused by other gliders or even by yourself, especially when flying low.
- It is not recommended to let go of the brakes below 100 meters, because a possible power unit malfunction may require immediate attention.
- In general, never trust your engine, as it can stop at any moment. Always fly prepared for engine failure.
- Unless it is absolutely necessary (e.g. collision avoidance), do not execute tight turns against the torque direction. Especially when climbing you can easily enter a stall or negative spin.
- Do not fly with tail wind at low altitudes - it narrows your options!
- Do not wait for the problem to grow - any change of engine sound or a vibration may indicate a problem. You'll never know until you land and check it out!
- Be certain of your navigation
- Remember that not everyone is fond of your engine noise.

If you have any doubts about flying conditions - do not begin.

If you have any questions, please contact your dealer or us.

Lastly, be equipped with a certified emergency parachute and helmet on every flight.



# 24 F3Bi - 36 - SKETCHES

## F3 Bi 36

RIB # GROUP	0	2	4	6	8	10	12	14	16	18	20	22	24	26	28	30	32	34	36	38	40	42	44	46	48	50	52	54	56	ST
<b>A's</b>	550	500		500	530		530	500		510	530		550	510		510	510		550	485		510	485				500		1340	
	2355		2330		2140		2120		1840		1800		1570		1435															
	5340						5495						5705						5735											
<b>B's</b>	550	500		500	530		530	500		510	530		550	510		510	510		550	485		510	485				880		6100	
	2355		2330		2140		2120		1840		1800		1570		1450															
	5255						5415						5640						5690											
<b>C's</b>	550	500		500	530		530	500		510	530		550	510		510	510		550	485		510	475				510		1390	
	2355		2330		2140		2120		1840		1790		1570		1440															
	5365						5530						5740						5765											
<b>D's</b>	550	500		500	530		530	500		510	530		550	500		510	500		550	485		510	465						1500	
	2355		2330		2140		2105		1840		1780		1570		1420															
	5535						5710						5890						5880											

<b>Brakes</b>	2060	1715	1585	1555	1495	1365	1380	1390	1525	1325	1185	1100
	1300		1300		1300		1300		2870			
	2200				2200				4085			

Line	Material	Diameter	DaN
Top	Dyneema	1.1	95
Mid	Super Aramid	1.9	320
Bottom A's, B's & ST	Super Aramid	2.5	450
ST Top	Super Aramid	1.8	230
Bottom C's & D's	Super Aramid	1.9	320
Brake top, Upped Mid, Lower Mid	Dyneema	1.1	95
Tip Steering	Dyneema	1.1	95
* Bottom Brake & 2D Brake	Dyneema	2.0	190

\* Marking point for knot on Br & 2D @ 290mm & 100mm

Drawn By	Walter Nesor	Item Code	00.000.000		Line Length Table	REV
Date	2021 05 12	Tolerance	±5mm			
Scale	Not to Scale	Name				
Approved	Jonathan Cohn					
APCO Aviation LTD			Model	F3 Bi	Size	36
						0.3



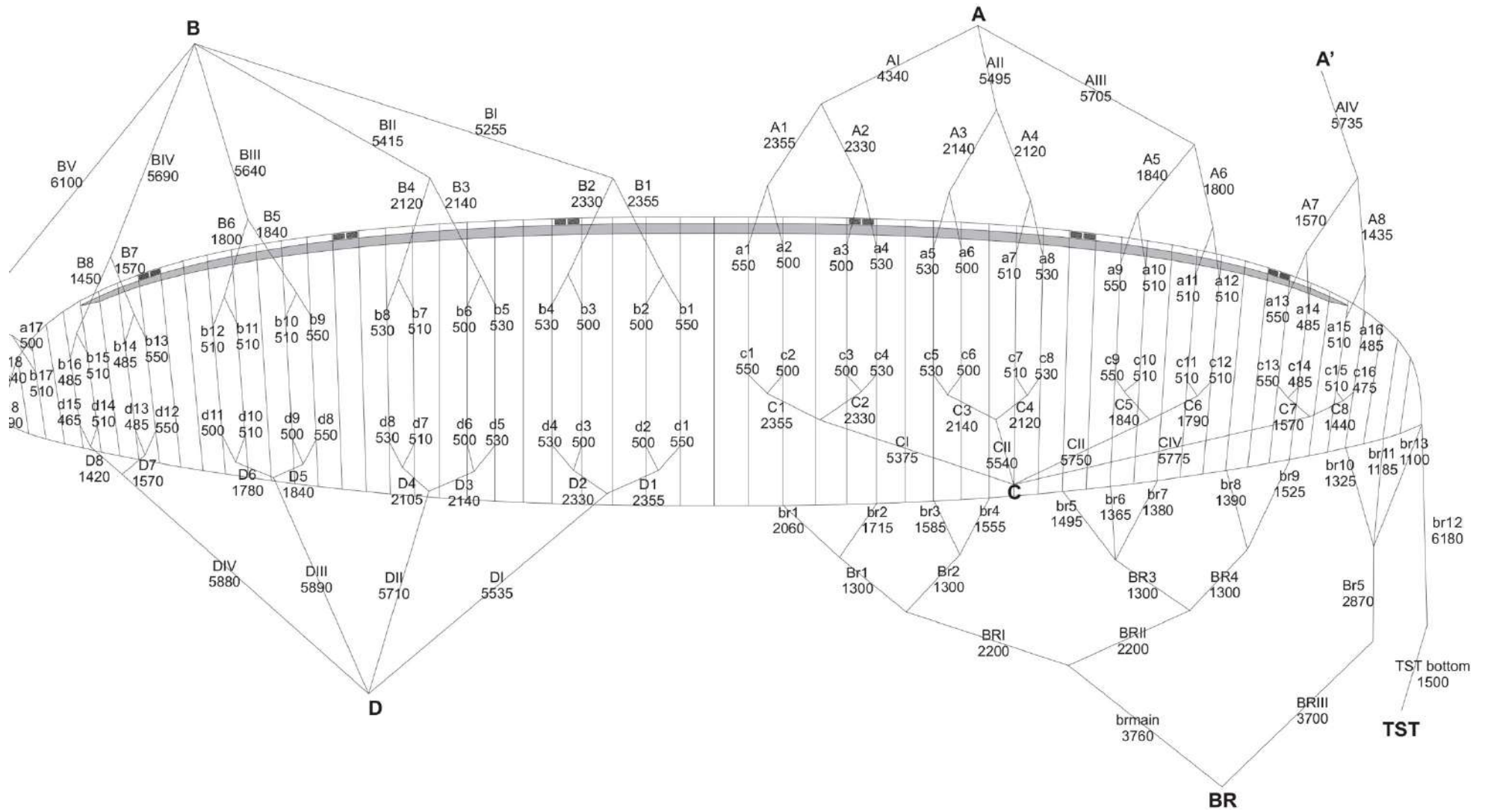



APCO wishes you many hours of enjoyable flying - Take Air!